

ACTIONPOWER

High Performance Grid Simulator

Cortex AC series

0V to 779V, 6kVA to 22kVA



Regenerative Grid Simulator

actionpowertest.com

HIGH DYNAMIC RESPONSE TIME

Advanced power conversion technology enables fast response speed of $3\text{V}/\mu\text{s}$ with high accuracy for voltage spike tests.

$3\text{V}/\mu\text{s}$
VOLTAGE SLEW RATE

$100\mu\text{s}$
RESPONSE TIME

3U

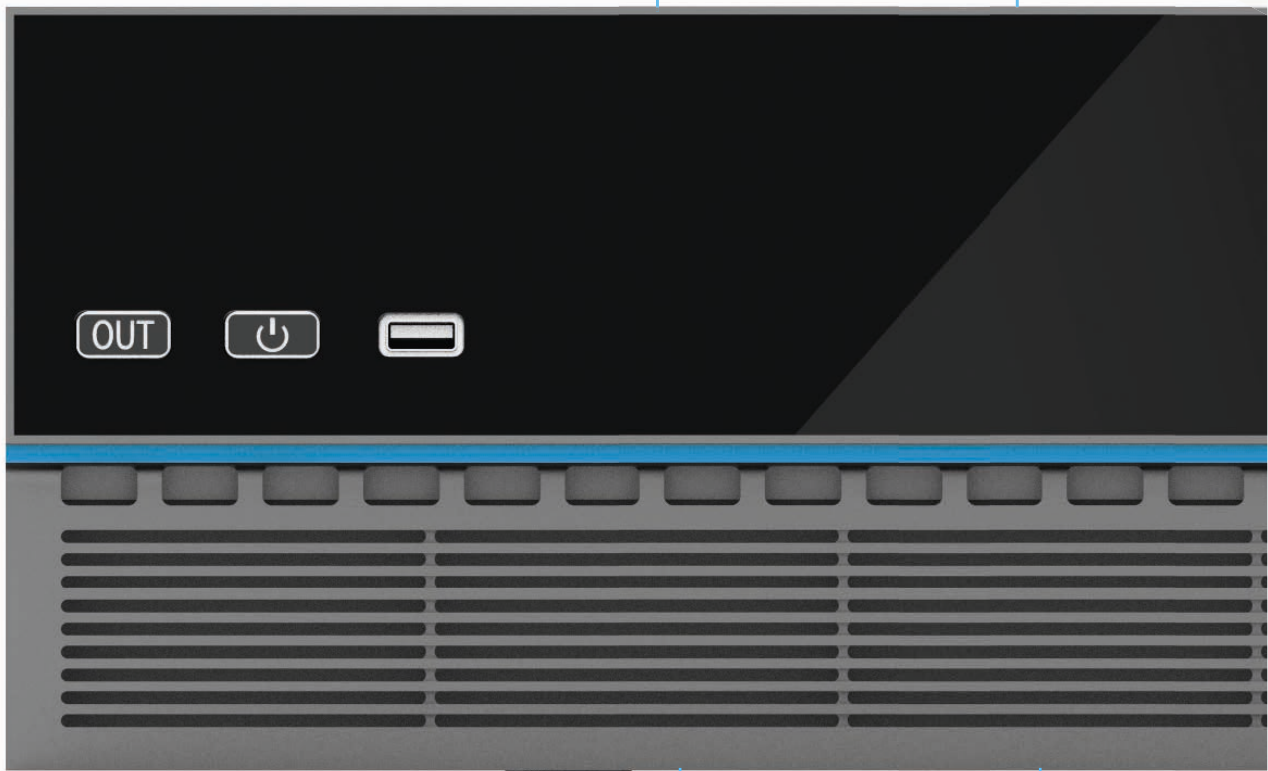

HIGH RESOLUTION WITH ACCURACY

Power density of Cortex AC series is up to $22\text{kVA}/3\text{U}$, and it can perform numerous application test using auto-ranging function, which adjusts the voltage and current range flexibly.

0.001Hz
FREQUENCY RESOLUTION

0.01V
VOLTAGE RESOLUTION

4
QUADRANT
CONTROL

RLC
REGENERATIVE
AC LOAD

FULLY TEST AC POWER WITH 4-QUADRANT

Full four-quadrant control enables reliable and efficient conversion of desired voltage and current, and AC load function with power regenerated to the grid.

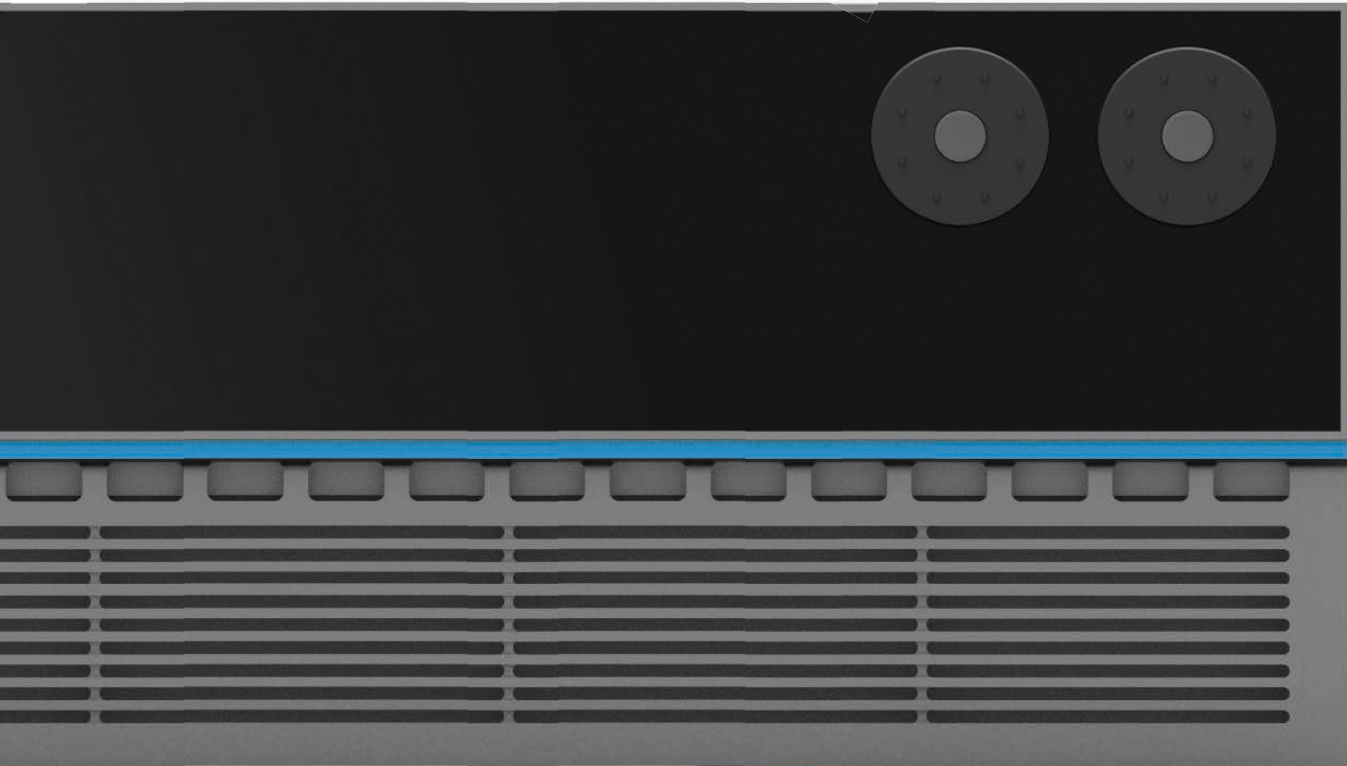

0.1°
PHASE ANGLE
RESOLUTION

359.9°
PHASE ANGLE
CONTROL

COMPREHENSIVE PHASE CONTROL

Simultaneous control of three phases up to 359.9° by unit angle of 0.1°, and phase angle of each of R, S, and T can be changed with the accuracy of 0.1%.

Ratings, types and voltages

Model	Power (kVA)	Voltage Range (LN_AC)	Frequency Range (Hz)	3-Phase Maximum Current (A)		1-Phase Maximum Current (A)		Voltage Range (V_DC)	Current Range (A_DC)
				rms	peak	rms	peak		
CA06-450	6	0-450	DC, 0.001-200	30	90	90	270	±636	±90
CA7.5-450	7.5	0-450	DC, 0.001-200	30	90	90	270	±636	±90
CA09-450	9	0-450	DC, 0.001-200	35	105	105	315	±636	±105
CA12-450	12	0-450	DC, 0.001-200	35	105	105	315	±636	±105
CA15-450	15	0-450	DC, 0.001-200	35	105	105	315	±636	±105
CA20-450	20	0-450	DC, 0.001-200	35	105	105	315	±636	±105
CA22-450	22	0-450	DC, 0.001-200	35	105	105	315	±636	±105

Regenerative 4-Quadrant AC Grid Simulator

The Cortex AC series is a programmable 4-quadrant grid simulator. It can test various grid-connected equipment by simulating AC power, and can also be used as an AC load. Moreover, it has the most advanced response speed, resolution, and accuracy, and is widely used in testing and research institutions.

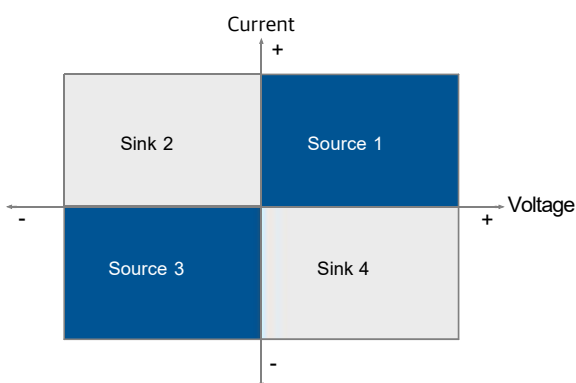

FEATURES

- 4-quadrant AC & DC Power Source
- AC & DC Electronic Load Function
- Fast Response Time : 3V/μs
- Constant Power Voltage Range : 0-779Vac (L-L)
- Frequency Change : DC, 0.001 to 200Hz
- Phase Angle Control : single & 3 phase
- Harmonic Injection : up to 100th order
- High Accuracy : ±(0.01%+0.05% F.S.)
- High Density : 22kVA / 3U
- Parallel Connection Available

Technical data

Specification	
Output Type	AC, DC, AC+DC, DC+AC
Working Mode	Regenerative, source & load integrated
Number of phases of output	Single-phase, three-phase, three phases independent
AC Input	
Voltage, Phases	304Vac to 480Vac / 380V±20%, 3ph+PE
Frequency	47Hz to 63Hz
Peak current	<1.5 * Rated Current
Power factor	0.99
Efficiency	>91%
AC Voltage Output	
Voltage range	L-N/0-450V@0.001-200Hz
Resolution	0.01V
Accuracy	±(0.01%+0.05% F.S.)
Waveform type	Sine, triangle wave, impulse wave, clipping wave, half wave, multi-wave, 30 groups of DST, user defined
DC component	<20mV
Load regulation	±0.05% F.S.
Line regulation	±0.01% F.S. @10%
Voltage slew rate	AC>3.0V/μs
Voltage distortion	<0.3%@50Hz/60Hz <1%@0.001Hz-200Hz
Voltage compensation	Adaptive
DC Voltage Output	
Accuracy	±(0.01%+0.05% F.S.)
Resolution	0.01V
Load regulation	±0.05% F.S.
Line regulation	±0.01% F.S. @10%
Voltage slew rate	DC>3.0V/μs
Frequency Output	
Accuracy	±0.01%
Resolution	0.001Hz
Range	0.001 - 200Hz
Phase Angle Control	
Accuracy	±0.1°@0.001-200Hz
Resolution	±0.1°
Phase angle range	0 - 359.9°
Phase control	Single-phase, Three-phase, Three-phase independent

Technical data

Specification		
Harmonic Injection		
Range	up to 100th order @ 40-70Hz fundamental frequency; up to 25th order @ 70-200Hz fundamental frequency;	
Content	40%	
Current		
Accuracy	$\pm(0.1\%+0.1\% \text{ F.S.})$	
Resolution	0.01A	
Internal Resistance Mode		
R range (a)	0-10	
L range (mH)	0-2	
Resolution	0.001	
Accuracy	$\pm 0.01\%+0.02\% \text{ F.S.}$	
RLC Load		
Resistance	Range (Ω)	0.001-1000
	Setting Resolution (Ω)	0.001
	Accuracy	$\pm 0.1\% \text{ F.S.}$
Inductance	Range (mH)	1-5000
	Setting Resolution (mH)	0.001
	Accuracy	$\pm 0.1\% \text{ F.S.}$
Capacitance	Range (μF)	1-5000
	Setting Resolution (μF)	0.001
	Accuracy	$\pm 0.1\% \text{ F.S.}$
Crest factor range	1.414 to 5	
Crest resolution	0.001	
Power factor range	-1 to 1	
Power resolution	0.001	
Transient Functions		
Programming	List, Wave, Step, Pulse, Advanced, Harmonics, Inter-harmonics, DST	
Time of step resolution	100 μs	
Number of programmed waveforms	50	
Analog programming	RMS, Amplitude, Instantaneous value(Amplifier mode)	
Environmental		
Cooling	Forced air cooling	
Temperature	Operating: 0 to 50°C	
Humidity	<80%, non-condensing	
Dimension & Weight		
Dimension (mm)	435(W) x 132(H) x 820(D)	
Weight	40kg	

Modular and Scalable Design

The Cortex AC series supports and adopts high-speed fiber optic communication technology, featuring strong anti-interference capability and zero latency, which enables modular capacity expansion through parallel operation. In particular, redundancy function ensures stable operation of the test system even in the event of fault at specific modules. That is in case of fault in any slave module, the system bypass the abnormal module and operate continuously so that secures the reliability and stability of the system by minimizing down-time.

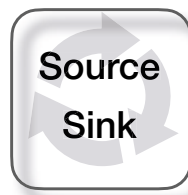
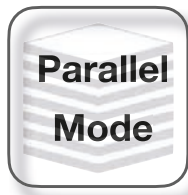

Features

- For 380V, 400V AC
- Modular Rack System
- Module Redundancy Function
- Cabinet System with 26U / 42U & 19 inch Rack
- Minimal Footprint : 3U / 22kVA
- Parallel Connection
- Extensive Protective Function (OVP, OCP, OTP, ...)
- Air Cooling

4-Quadrant Control

With four-quadrant control, Cortex AC series can test PV inverters, V2G, EV chargers, EVSE, batteries, UPS, and AC/DC power supplies. It has a built-in load option as standard and can operate in any four-quadrant with programmable phase control. It can simulate inductive and capacitive loads, allowing you to test a full range of AC power loads.

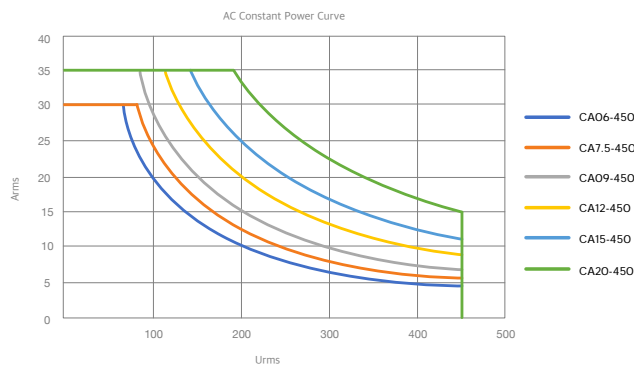
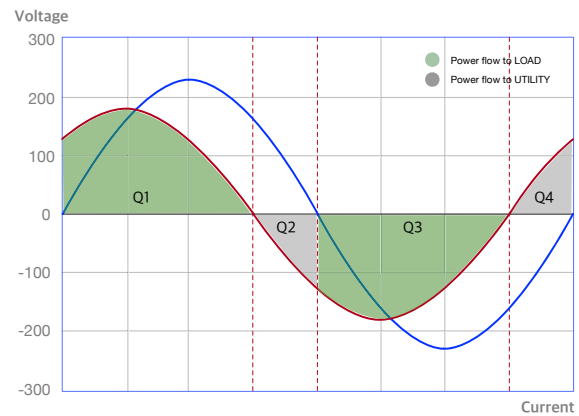
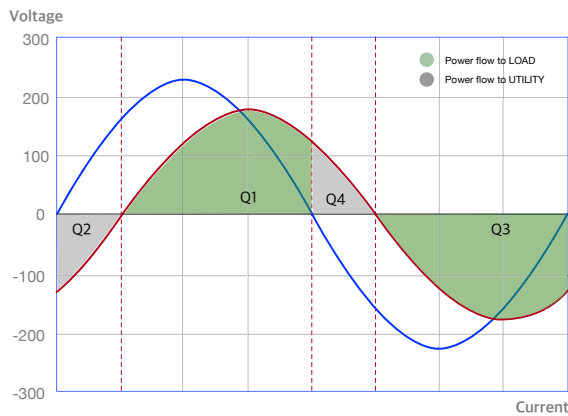

The Cortex AC series provides a wide voltage range through a designated power curve so that it can perform the test at the condition of both high and low voltage range.

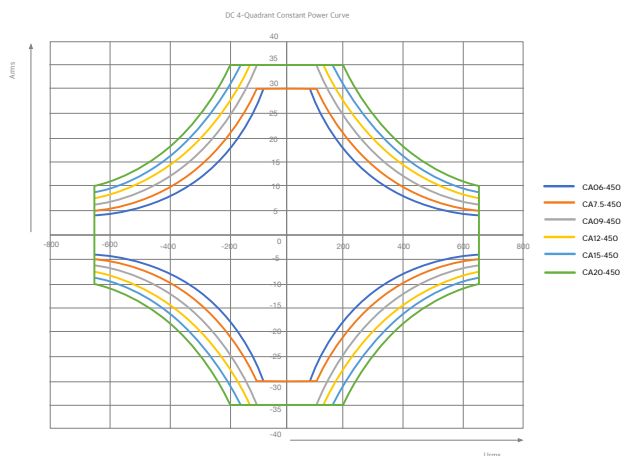

The Cortex AC series applies advanced power conversion technology to provide AC output as well as DC output modes. The DC maximum average output current is the same as the AC RMS value and can be operated in four quadrant states. That is Cortex AC series have the advantage of higher output power, while a typical AC power supply can only supply half of the AC RMS output value.

RLC network simulation function

In addition to power supply functions, the Cortex AC series can be used as a linear load simulator and for a variety of purposes based on the power regeneration function. The Cortex AC series features up to 12 built-in RLC network models and can simulate linear load characteristics with flexible parameters to test product performance under different impedances, three-phase balanced and unbalanced load modes.

For products that require off-grid testing, such as OBC, UPS, ESS converter, etc., the RLC load function of the Cortex AC series can be used to realize the source-to-load function conversion of the device, which greatly simplifies the ATE hardware configuration and realizes V2G, V2L, V2H and other tests at the same time.

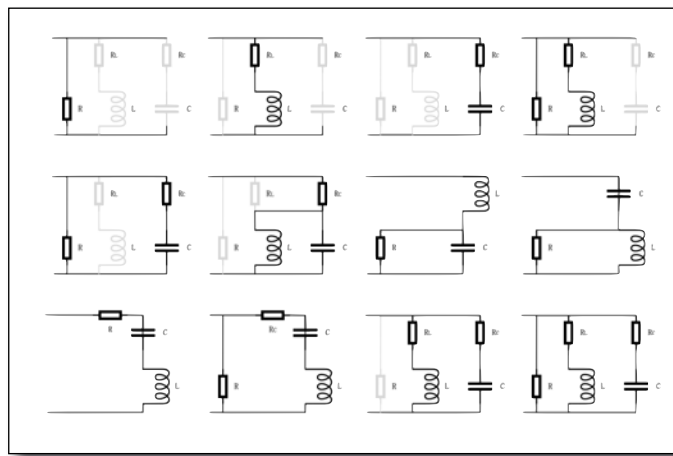

RLC load models

Anti-islanding test function

In addition to grid simulation functions, the Cortex AC Series is an alternative to RLC loads, meeting the diverse test requirements of modern energy-related industries for linear load simulation, anti-islanding protection, and off-grid operation.

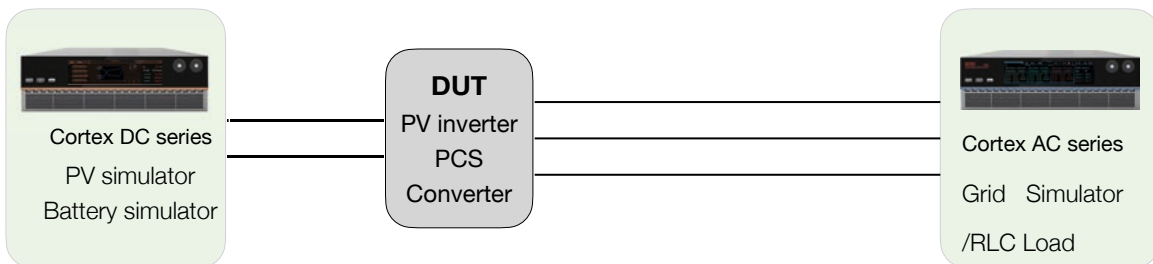

Powerful standard waveform library

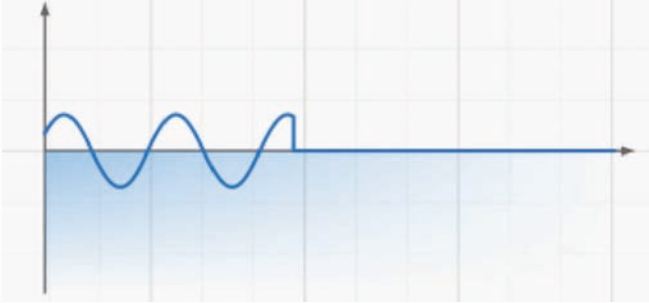

IEC61000-4-11
Interruption 90°@Class2/50Hz

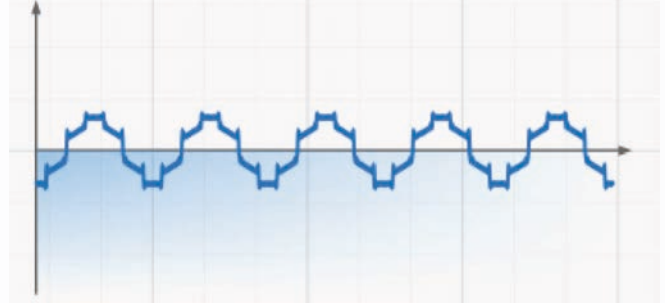

IEC61000-4-13
Odd harmonics that are not multiples of 3
@Class3/50Hz

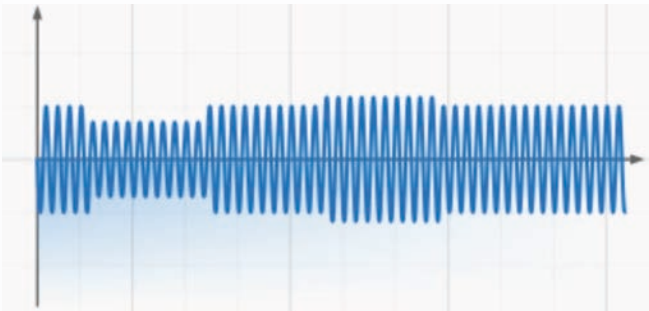

IEC61000-4-14
+20%-30% voltage fluctuation time time interval
0.2s@Class3/50Hz



IEC61000-4-17
DC ripple voltage@Class3

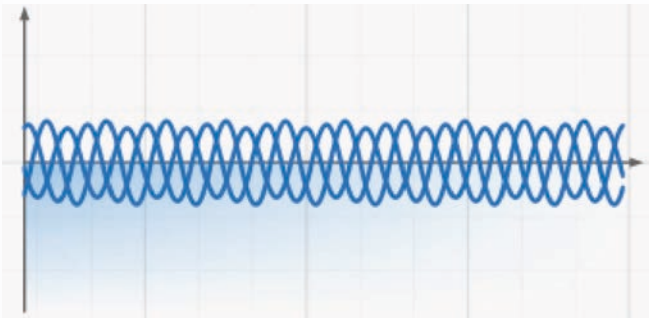

IEC61000-4-27
Voltage unbalance@Class3

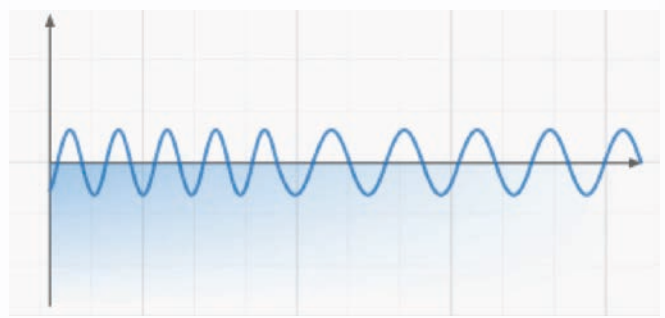

IEC61000-4-28
Power frequency variation@Class4

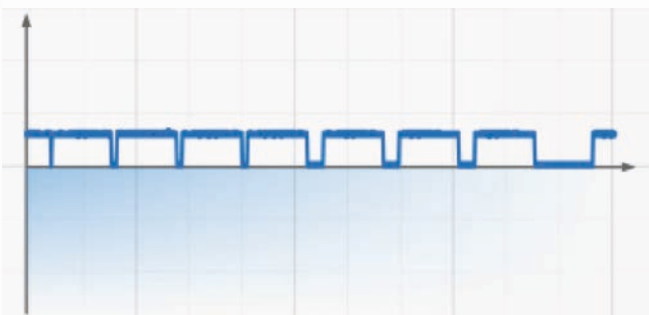

IEC61000-4-29
DC interruption

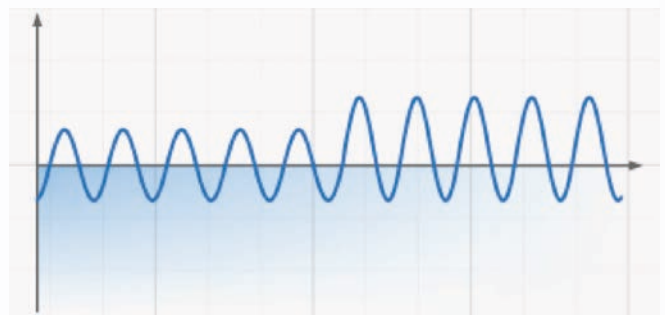

T/CPSS1007-2020
20V surge 10 cycles,
Half cycle voltage multiplication



Powerful standard waveform library

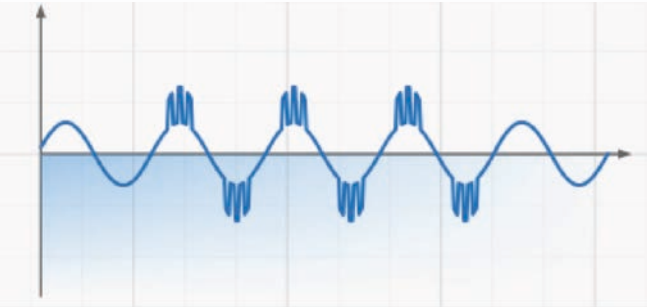

T/CPSS1007-2020
220V sudden increase to 440V,
3 cycles abnormal

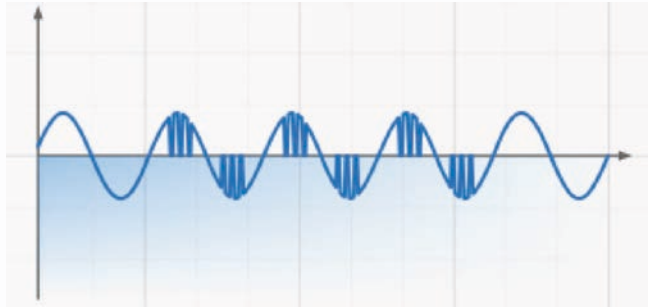

T/CPSS1007-2020
290V drop to 5V, 3 cycles abnormal
10 cycles normal

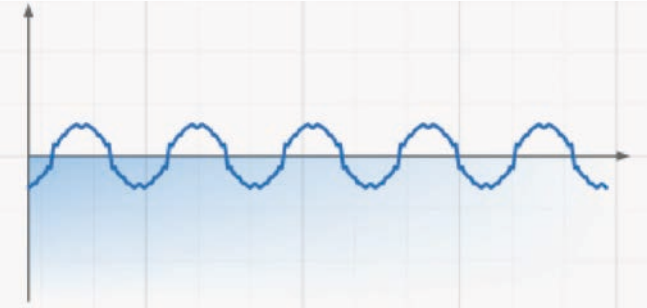

DST10 waveform

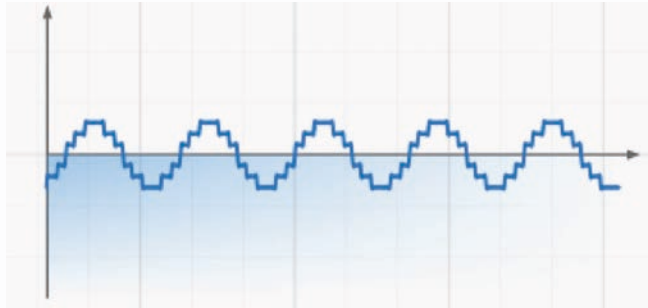

DST26 waveform

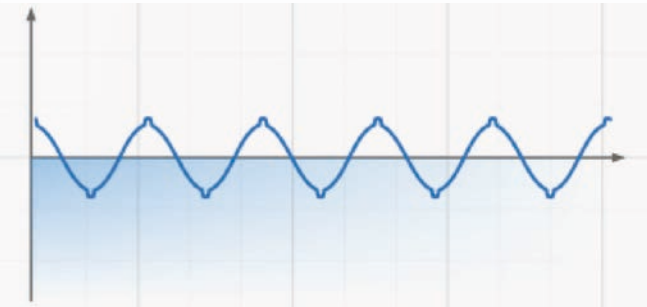

DST23 waveform

Waveforms

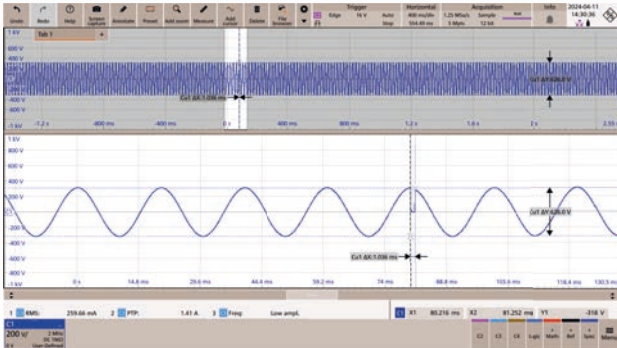

1ms interruption

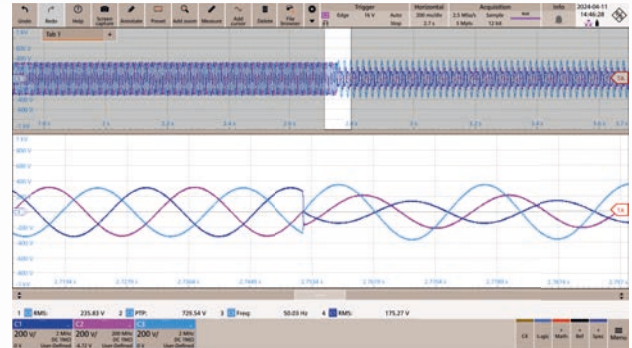

Single phase change

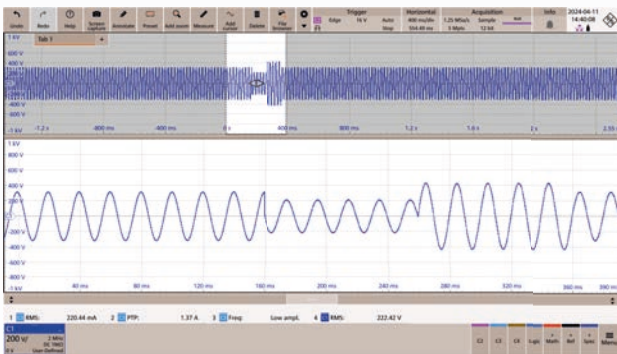

Phase shift

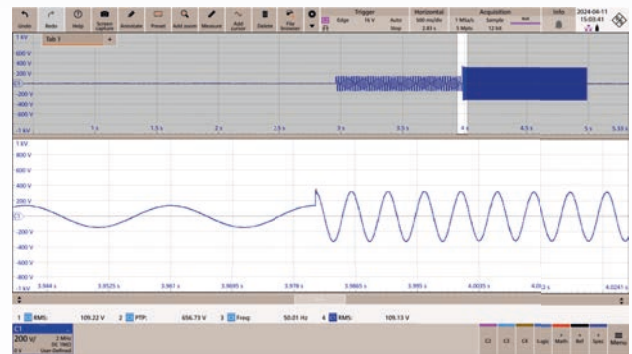

Frequency change

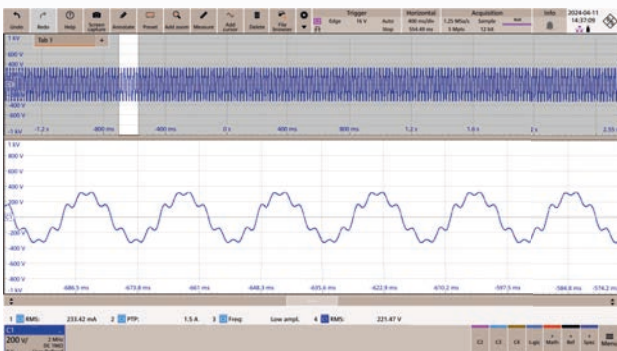

Harmonic injection

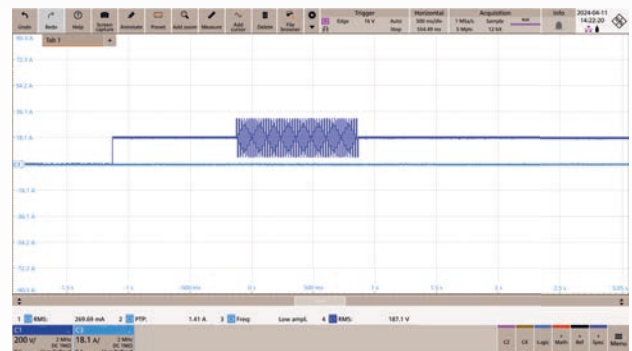

DC+AC output

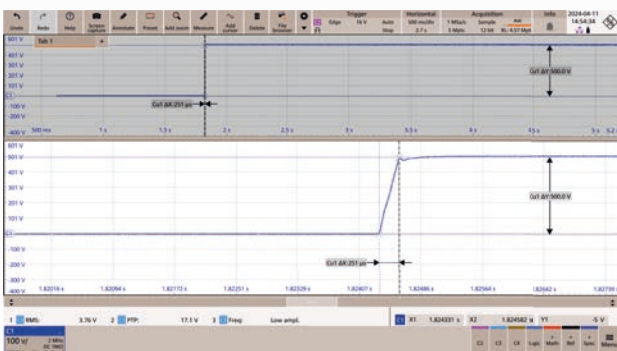

Dynamic response time : 251 μ s

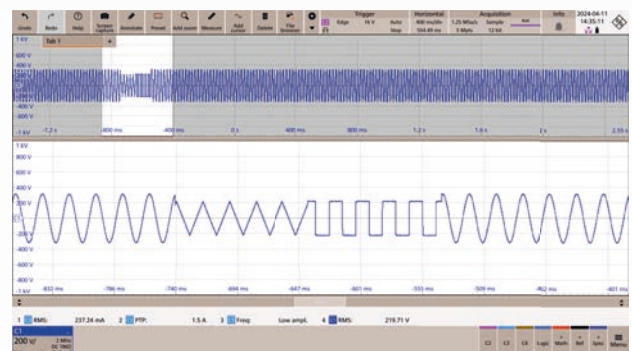

Programming output

Application

The Cortex AC series is an innovative product used in a variety of applications due to its unique technology and optimal performance. It can perform bidirectional AC power supply and act as regenerative AC loads, which can be utilized for long-term reliability testing applications including tests for ESS, PV inverter, wind turbine, electric vehicle DC charging stations, and a variety of grid-connected systems. They are particularly well suited for applications that require accurate and extremely fast response times when simulating AC power characteristics.



ESS Testing



PV Inverter Testing



Wind Turbine Testing

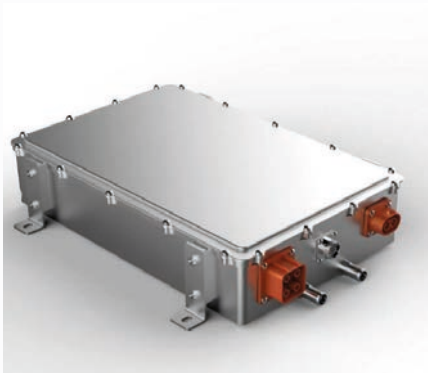

AC/DC Power Supply Testing

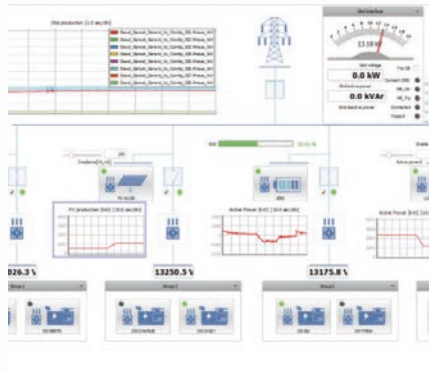

Power HiL



EV Charger & EVSE Testing

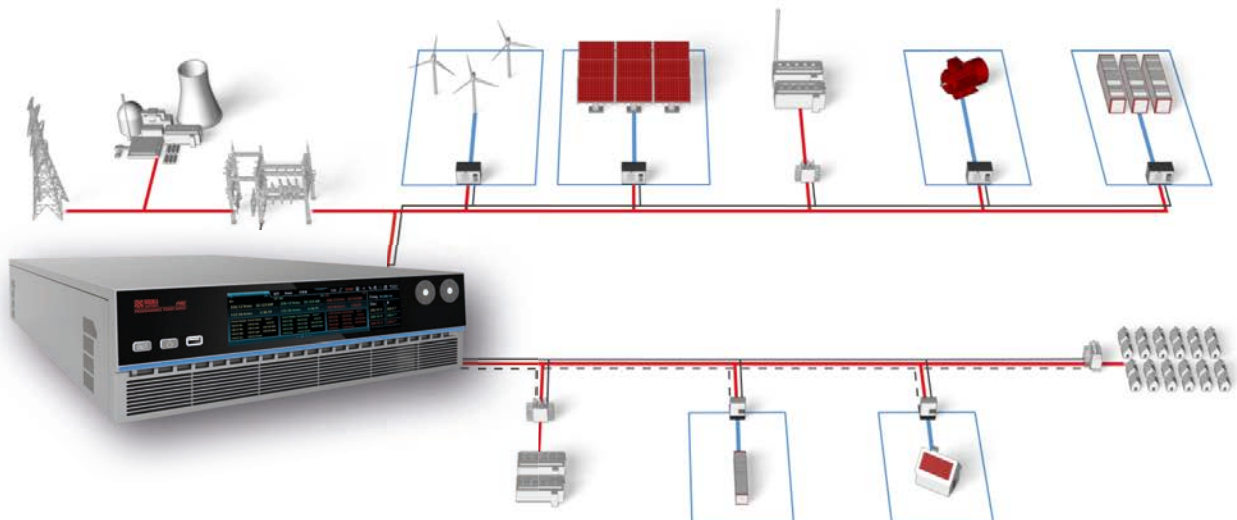

Powerful Software



Provides Diverse Simulation Modes

Low Voltage Ride-Through (LVRT) and Area Electrical Power System (EPS) Disturbance Simulation

Cortex AC series can easily simulate tests such as LVRT test patterns with provided software, accurately control user-defined waveforms, and add features depending on the test environments.

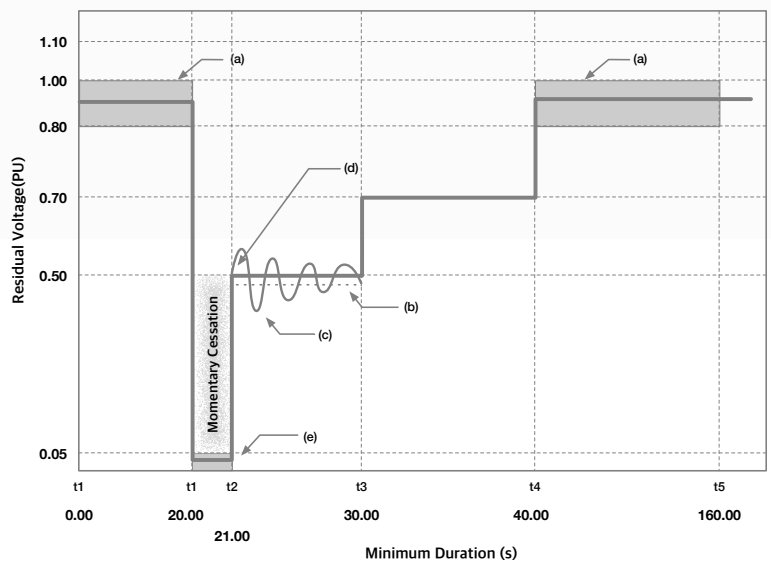

Panel Description

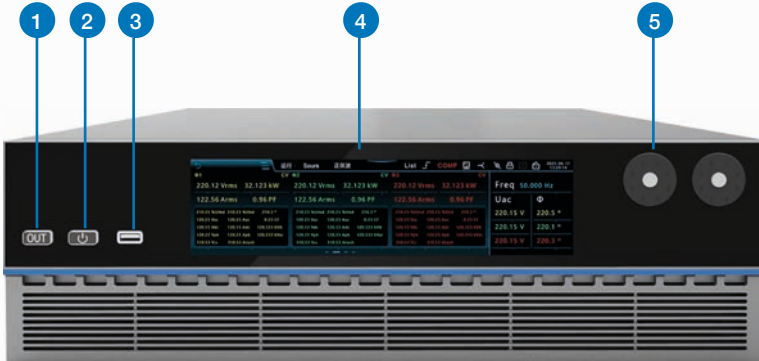

1. Power Output Button
2. Power On / Reset Button
Device on/off switch
3. USB Port
External Storage Interface
4. 8.8" FHD Touch Screen
Display setting and measurement data
5. Pushable Knob
To edit the settings on-screen

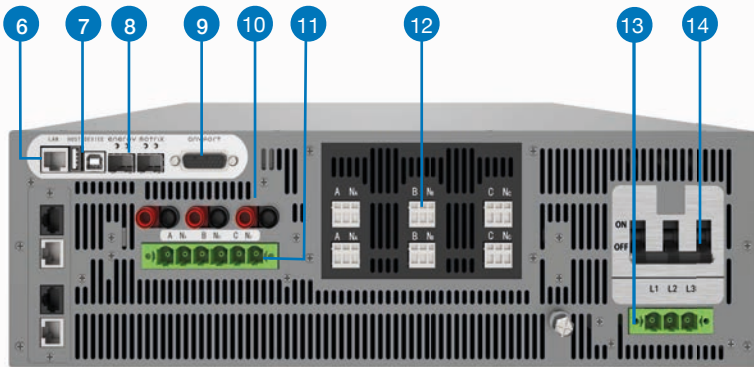

6. LAN Interface
7. USB Interface
8. Energy Matrix Interface
Parallel connection
9. Anyport Interface
10. Output Measurement Terminal
11. Voltage Output
12. Voltage Compensation Terminal
13. AC input & PE Terminal
14. AC Circuit Breaker
AC power on/off

Dimension

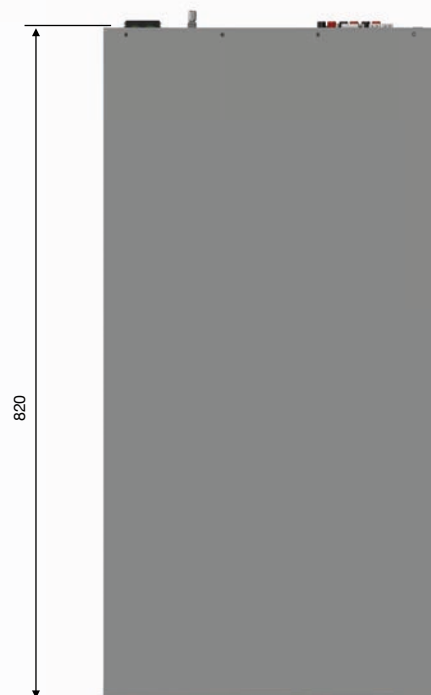
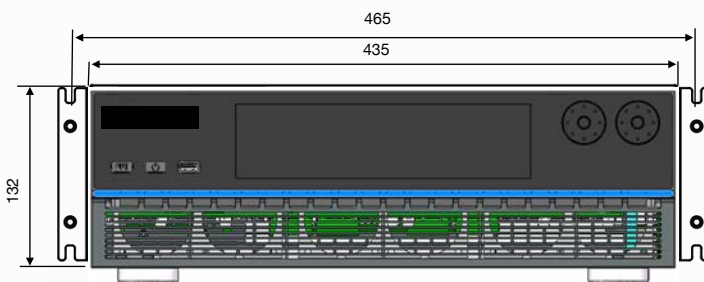

ACTIONPOWER

For more information, please contact
your local ACTION POWER distributor or visit

www.actionpowertest.com

© Copyright 2026 ACTIONPOWER. All rights reserved.
Specifications subject to change without notice.

Headquarters

No.3333 Run De RD., Chang An District, Xi'an Shaanxi, China 710119

info@actionpowertest.com

+86 (0)29-8569-1870